

PERFORERTE STÅL- OG METALLPLATER

F. Burmeister lagerfører perforerte plater i et stort antall mønstre og dimensjoner i følgende materialer:

- Ubehandlet stål
- Sendzimir galvanisert stål
- Varmgalvanisert stål
- Rustfritt stål, kvalitet AISI 304
- Syrefast stål, kvalitet AISI 316
- Aluminium

Ved forespørsel og bestilling av perforerte plater vennligst oppgi følgende spesifikasjoner:

- Metalltype
- Platetykkelse
- Perforering: runde hull, firkanthull eller mønster
- Hull- eller mønsterstørrelse



Merk at det ikke er teknisk mulig å fremstille perforerte plater med runde hull som er mindre enn platetykkelsen. (F.eks. min. 2 mm runde hull i en 2 mm tykk plate.)

Gjennom et omfattende kontaktnett til norske og utenlandske produsenter kan vi på kort tid skaffe perforerte plater med andre spesifikasjoner enn de som er nevnt i vår katalog: f.eks plater med firkantdeling (like rekker), andre metallkvaliteter eller med spesielle mål, tykkelser og mønstre.

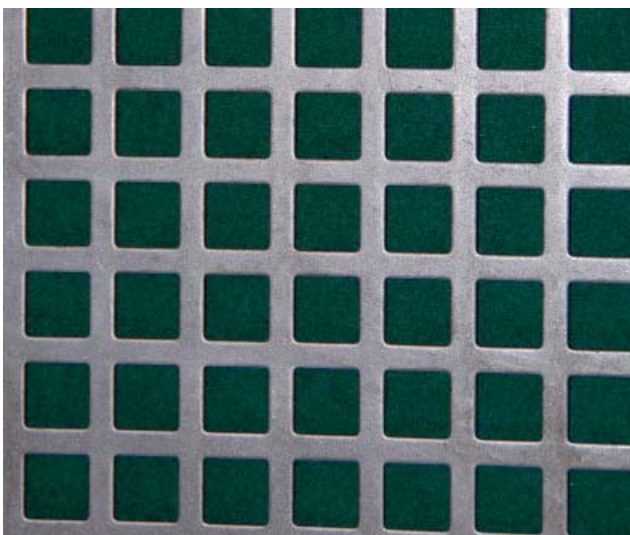
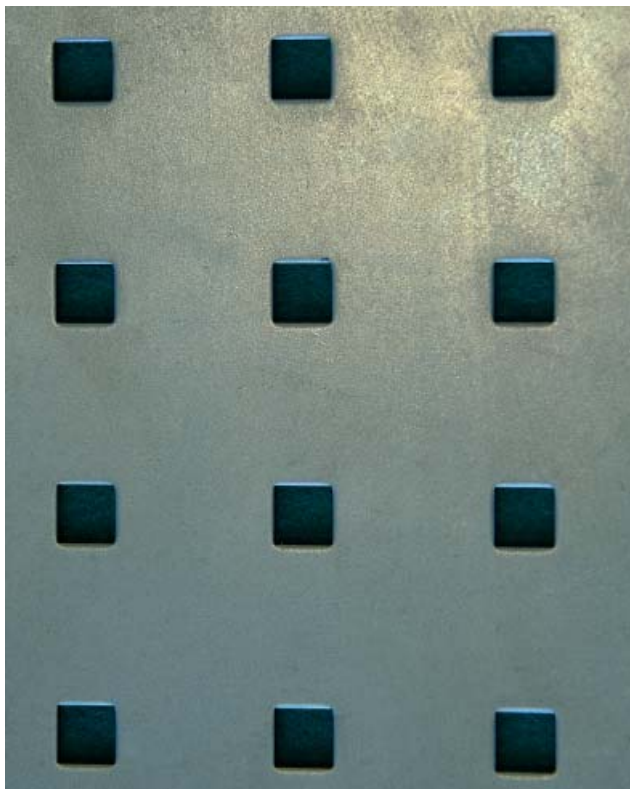
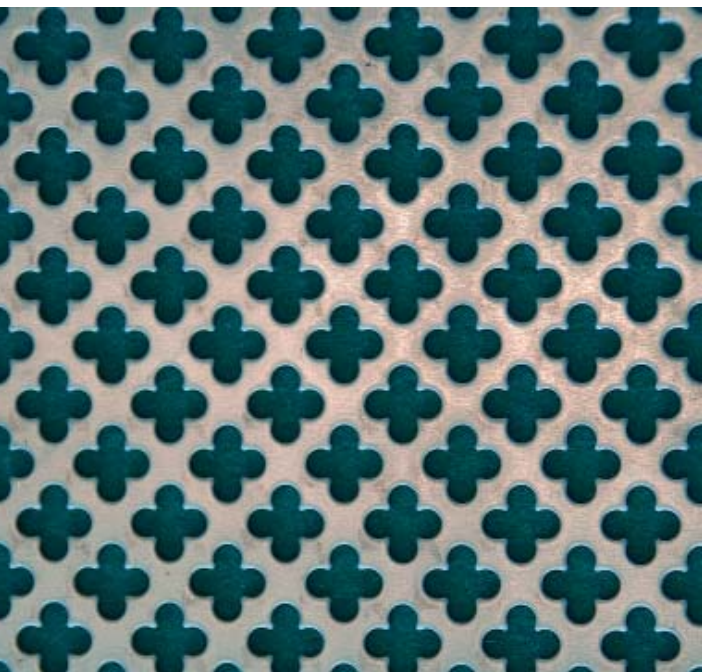

Målestokk 1:1

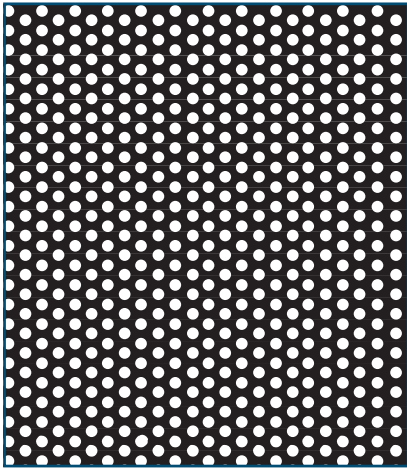

Rv 1,5-2,5

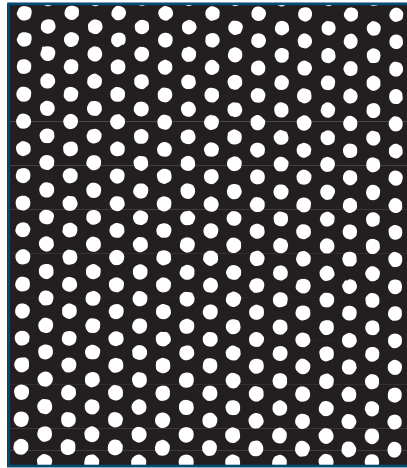

Rv 2-3,5

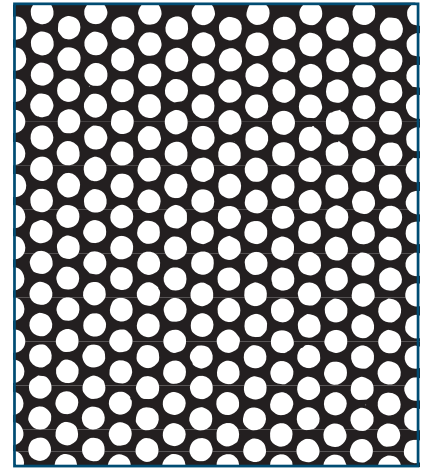

Rv 3-5

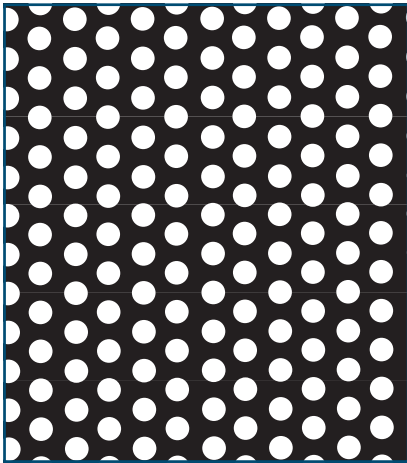

Rv 3-6

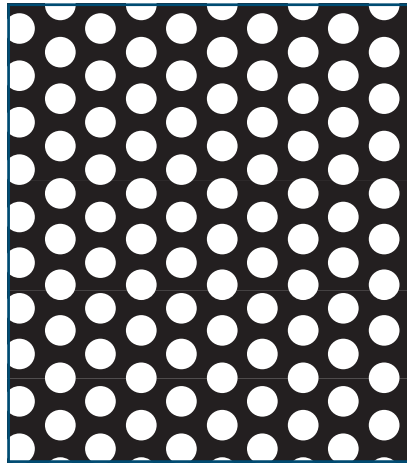

Rv 3,5-6

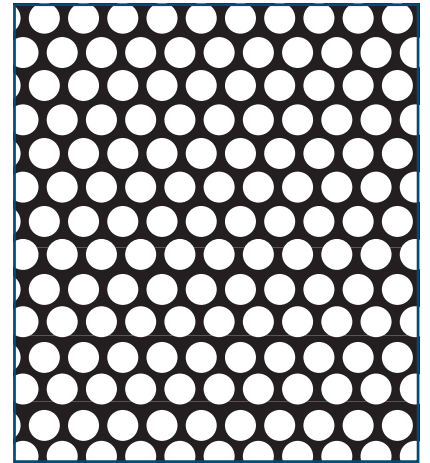

Rv 4-6

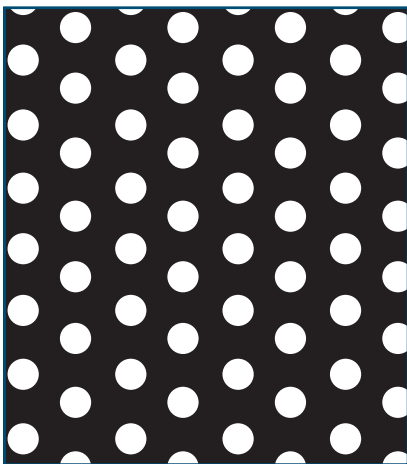

Rv 4-8

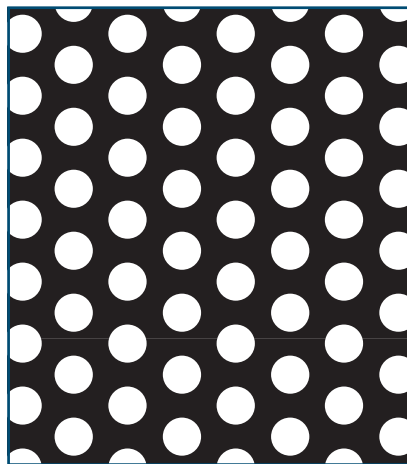

Rv 5-8

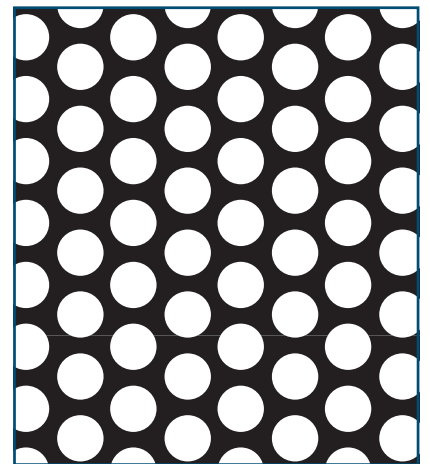

Rv 6-8

ORIGINALE PERFORERINGER

Målestokk 1:1

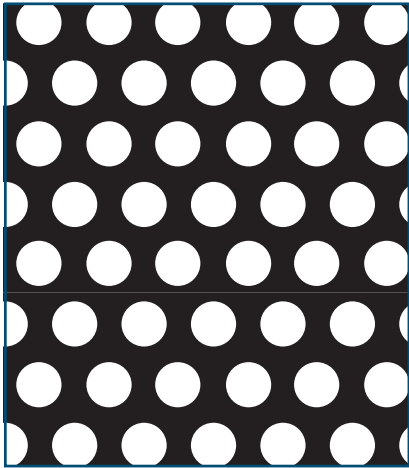

Rv 6-9

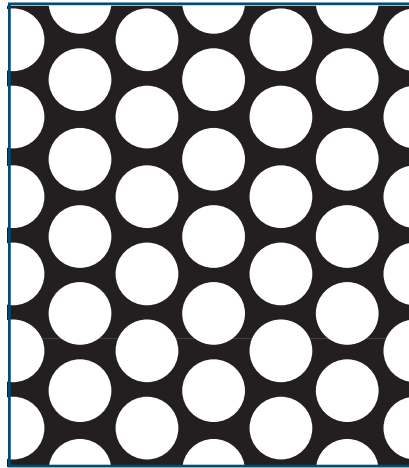

Rv 8-10

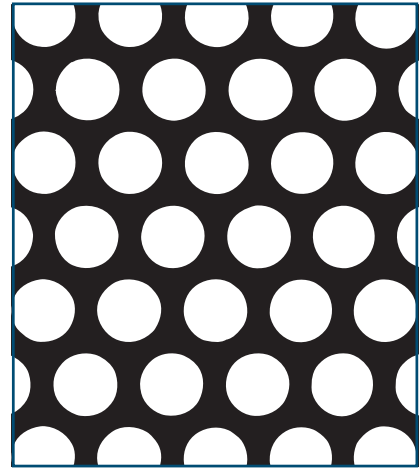

Rv 8-11

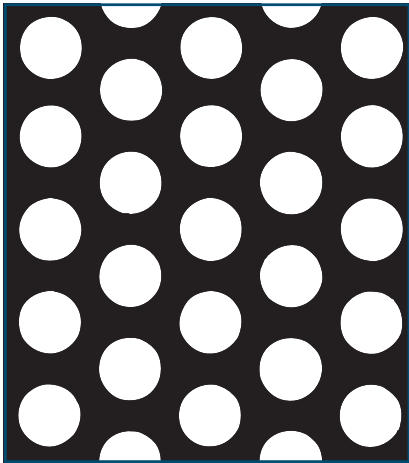

Rv 8-12

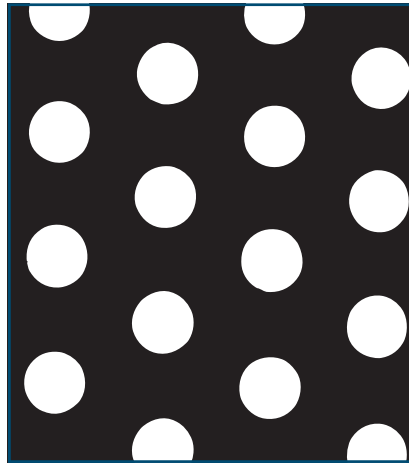

Rv 8-16

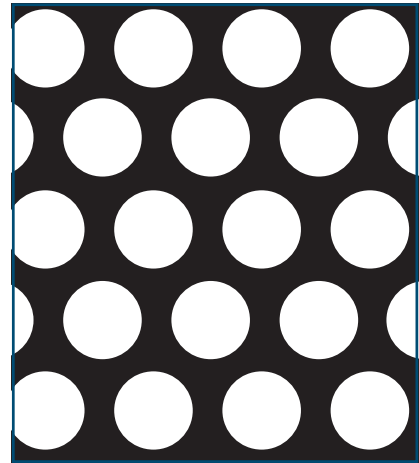

Rv 10-14

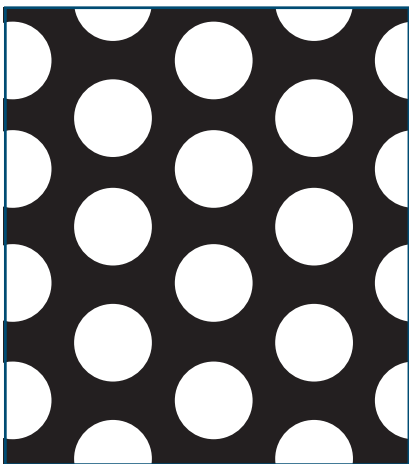

Rv 10-15

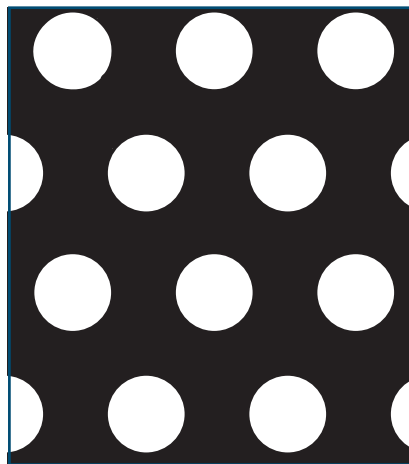

Rv 10-18

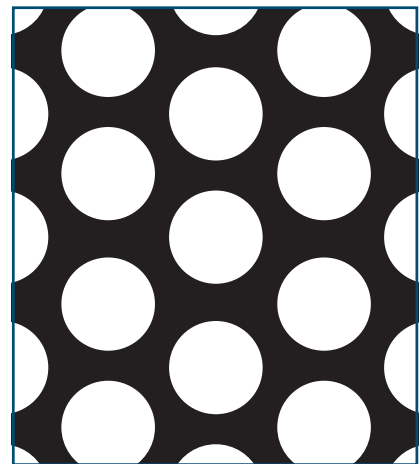

Rv 12-16

Målestokk 1:1 (unntatt rotting)

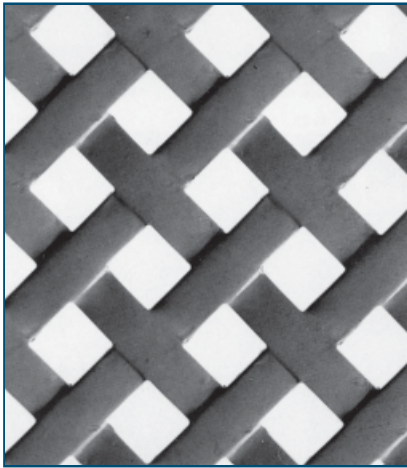

Rotting

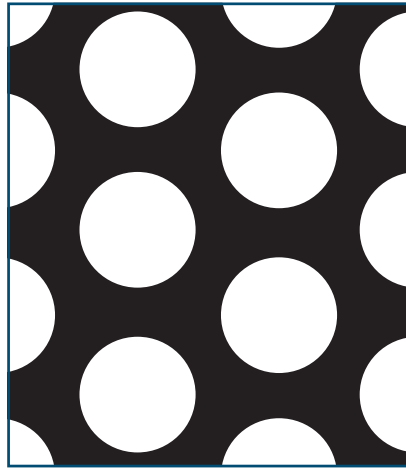

Rv 15-21

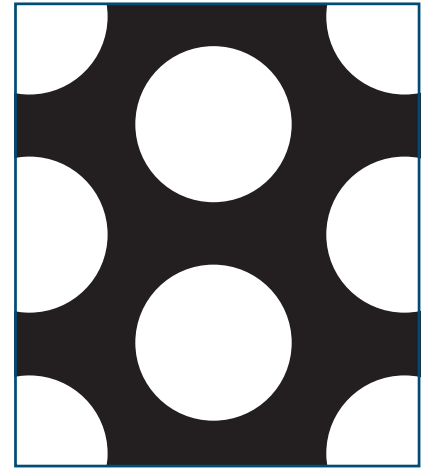

Rv 20-28

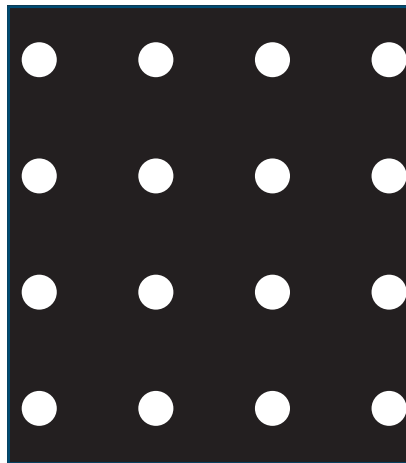

Rg 4,5-15

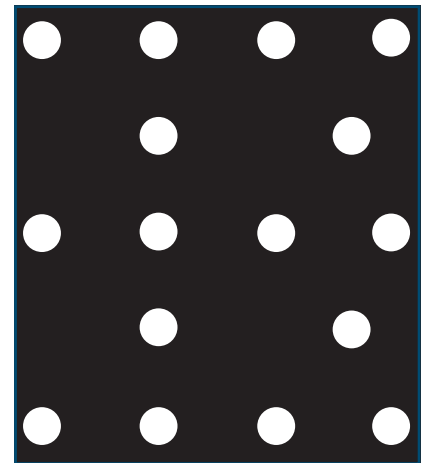

Europ perforering



Lv 5-20

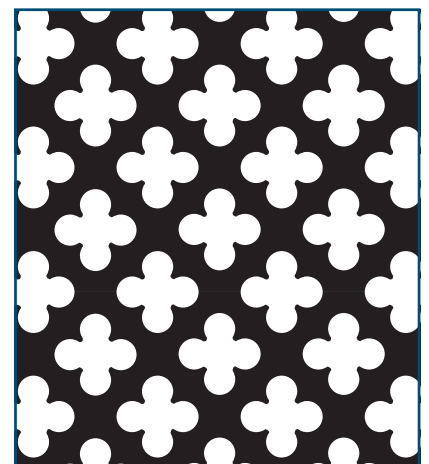

Kløver

Målestokk 1:1

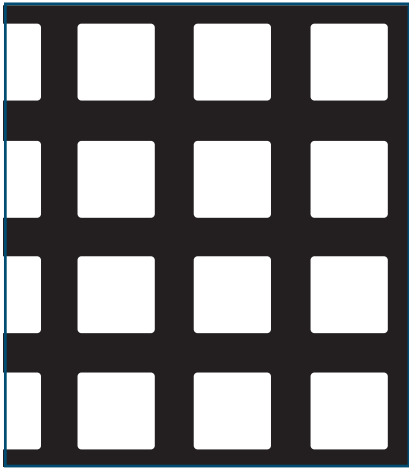

Qg 10-15

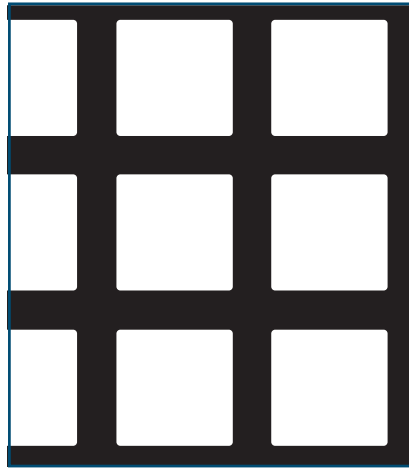

Qg 15-20

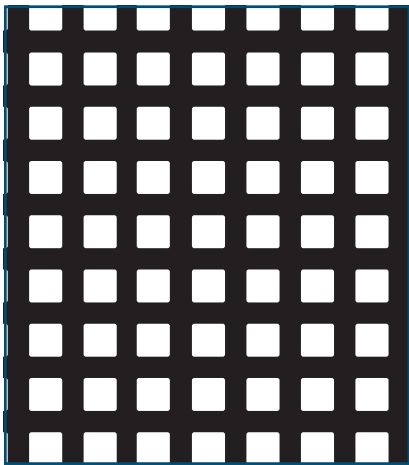

Qg 4-7

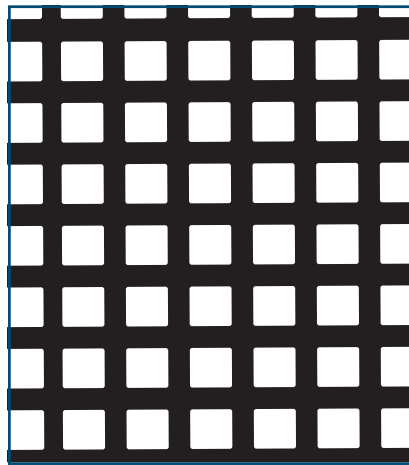

Qg 5-8

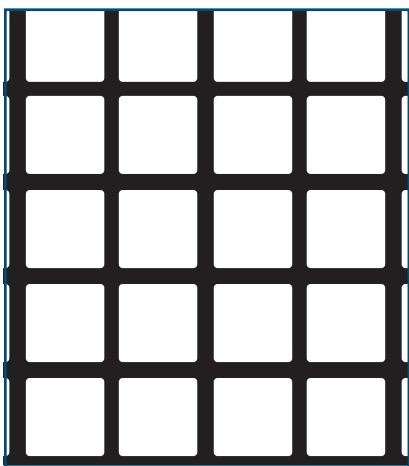

Qg 10-12

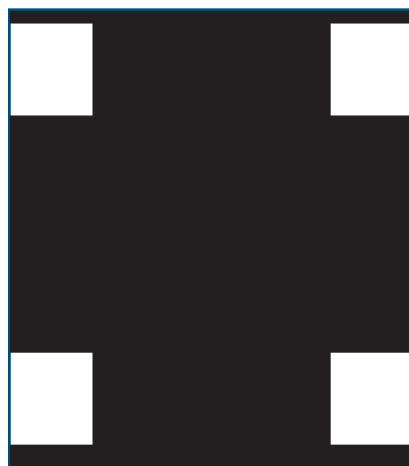

Qg 9,2-34



FORMLER

DIN-Betegnelser

- Rv = Runde hull triangeldeling
- Rg = Runde hull firkantsdeling
- Qg = Firkantsperforering firkantsdeling
- Lv = Slisseperforering triangeldeling

$$a_2 = x \cdot u + w$$

$$x = \text{antall } u - \text{avstand, } u = 0.866 t$$

$$b_2 = y \cdot v + w$$

$$y = \text{antall } v - \text{avstand, } v = 0.5 t$$

Relativt åpent areal

$$a_0 = \frac{90,7 \cdot w^2}{t^2} \text{ i \%}$$

Antall hull per m²

$$n = \frac{1,15 \cdot 10^6}{t^2}$$

Utregning av deling t på grunnlag av hull per flate

$$t = \frac{1,15 \cdot 10^6}{n} = \frac{F \cdot 1,15 \cdot 10^6}{N} \quad \leftarrow \text{Eksempel}$$

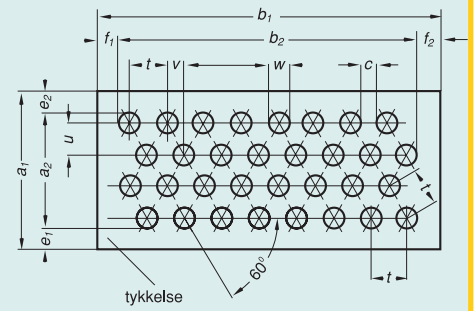

Rv Runde hull triangeldeling

Rv 5 - 8

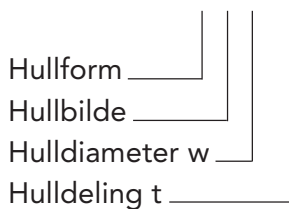

$$a_2 = x_1 \cdot u + w$$

$$x_1 = \text{antall } t - \text{avstand parallell til } a_2$$

$$b_2 = x_2 \cdot t + w$$

$$x_2 = \text{antall } t - \text{avstand parallell til } b_2$$

$$t = w + c$$

Relativt åpent areal

$$a_0 = \frac{78,5 \cdot w^2}{t^2} \text{ i \%}$$

Antall hull per m²

$$n = \frac{10^6}{t^2}$$

$$t = \frac{10^6}{n} = \frac{F \cdot 10^6}{N}$$

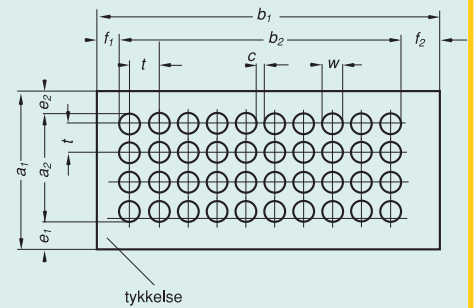

Rg Runde hull firkantsdeling

Qg 10-15

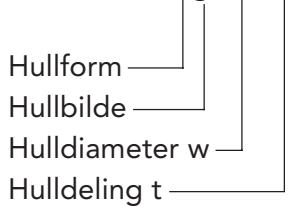

$$a_2 = x_1 \cdot t + w$$

$$x_1 = \text{antall } t - \text{avstand parallell til } a_2$$

$$b_1 = x_2 \cdot t + w$$

$$x_2 = \text{antall } t - \text{avstand parallell til } b_2$$

$$t = w + c$$

$$r_{\text{max}} = 0,15 \cdot w$$

Relativt åpent areal

$$a_0 = \frac{100 \cdot w^2}{t^2} \text{ i \%}$$

Antall hull per m²

$$n = \frac{10^6}{t^2}$$

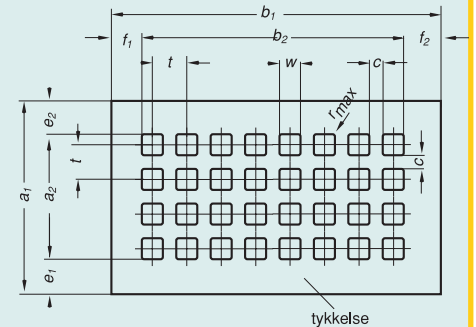

Qg Firkantsperforering firkantsdeling

FORMLER

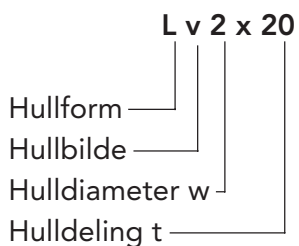

$$b_2 = x \cdot u + l$$

x = antall t - avstand parallell til b_2

$$a^2 = y \cdot t_1 + w$$

y = antall t - avstand parallell til a_2

$$u = 0,5 t_2 \quad t_1 = w + c_1 \quad t_2 = l + c_2$$

Relativt åpent areal

$$a_0 \text{ i } \% = \frac{w \cdot l - 0,215 \cdot w^2}{t^1 \cdot t^2} \cdot 100 \text{ i } \%$$

Antall slisser per m²

$$n = \frac{10^6}{t^1 \cdot t^2}$$

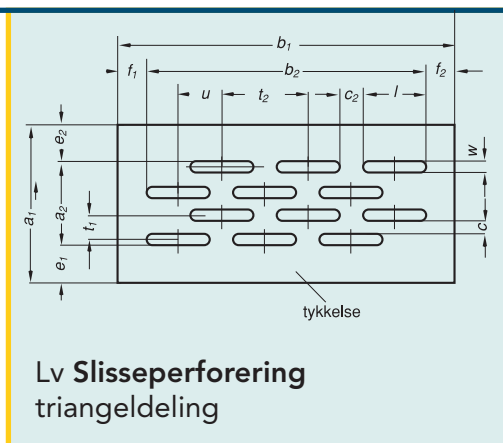

Uperforete kanter på lagerplater

Lagerplatene leveres normalt med en uperforet kant på 5 - 10 mm rundt.

Det kan også forekomme at platene ikke har noen uperforet kant på kortsidene, d.v.s. at snittet kan gå igjennom perforeringen. Ved platetykkelser på mer enn 3 mm er den uperforete kanten ca. 25 mm på en langside eller rundt.

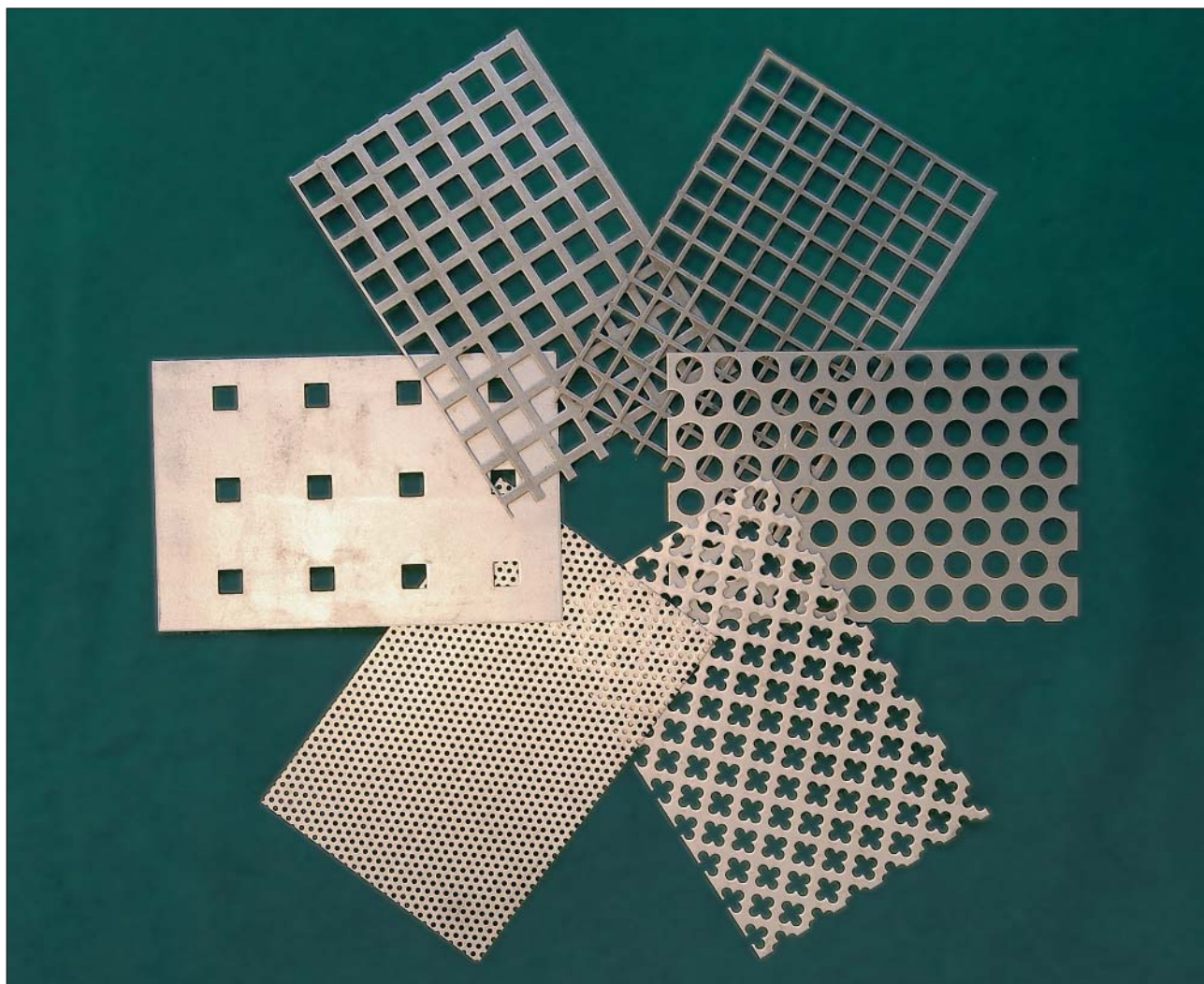

EKSEMPLER PÅ HULLBILDER

Materiale: SS 1142/St 12.03 DIN 1623
 SS 1312/StW 22 DIN 1541

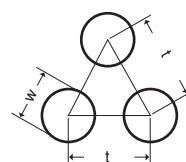

Runde hull triangeldeling

(DIN 24041) Rv	w - t	a0* i %	1000 x 2000 mm tykk. i mm						1250 x 2500 mm tykk. i mm				1500 x 3000 mm tykk. i mm				
Rv 1,1 - 2,0		27,4	0,75	1,0													
Rv 1,5 - 2,5		32,7	0,75	1,0	1,5				1,0								
Rv 1,5 - 3,0		22,7	1,0	1,5					1,0								
Rv 2,0 - 3,0		40,3	1,0						1,0								
Rv 2,0 - 3,5		29,6	0,75	1,0	1,5	2,0			1,0	1,5							
Rv 2,5 - 4,0		35,4	1,0	1,5	2,0												
Rv 3,0 - 4,0		51,0	1,0	2,0					1,0								
Rv 3,0 - 5,0		32,7	0,75	1,0	1,5	2,0	3,0		1,0	1,5	2,0		1,0	1,5			
Rv 3,0 - 6,0		22,7	1,0	2,0	3,0												
Rv 4,0 - 6,0		40,3	1,0	1,5	2,0	3,0			2,0				2,0	3,0			
Rv 4,0 - 8,0		22,7	1,5	2,0													
Rv 5,0 - 6,0		63,0	1,0														
Rv 5,0 - 7,0		46,3	1,0	1,5													
Rv 5,0 - 8,0		35,4	1,0	1,5	2,0	3,0	4,0	5,0	1,0	1,5	2,0	3,0	1,0	1,5	2,0	3,0	
Rv 5,0 - 9,0		28,0	5,0														
Rv 6,0 - 9,0		40,3	1,0	1,5	2,0	3,0			2,0				1,5				
Rv 8,0 - 10,0		58,0	1,0														
Rv 8,0 - 11,0		48,0	1,0	1,5	2,0												
Rv 8,0 - 12,0		40,3	1,0	1,5	2,0	3,0	4,0	6,0	1,5	2,0			1,5				
Rv 8,0 - 15,0		22,7	8,0														
Rv 9,0 - 12,0		51,0	1,0														
Rv 10,0 - 13,0		53,7	1,0	1,5													
Rv 10,0 - 14,0		46,3	1,0	1,5	2,0												
Rv 10,0 - 15,0		40,3	1,0	1,5	2,0	3,0	4,0	5,0	1,0	1,5	2,0		1,5	2,0			
Rv 10,0 - 18,0		28,0	10,0														
Rv 12,0 - 16,0		51,0	1,0	1,5	2,0	3,0	4,0		1,5								
Rv 15,0 - 21,0		46,3	1,5	2,0	3,0				2,0				2,0				
Rv 20,0 - 25,0		58,0											1,5				
Rv 20,0 - 28,0		46,3	1,5	2,0	3,0	4,0			2,0				1,5	2,0			
Rv 30,0 - 40,0		51,0							2,0								

Runde hull firkantdeling

(DIN 24041) Rv	w - t	a0* i %	1000 x 2000 mm tykk. i mm						1250 x 2500 mm tykk. i mm				1500 x 3000 mm tykk. i mm				
Rg 4,5 - 15,00		7,1	1,0	1,5					1,0	1,5			1,5				
Rg 10,0 - 20,78		18,18	2,0						2,0								
Rg 10,0 - 25,98		11,63	2,0						2,0								
Rg 15,0 - 36,38		13,35	2,0						2,0								
Rg 20,0 - 48,50		13,35	2,0						2,0								

Vekt pr. m² = 8 kg x tykkelsen - Ao% (luft prosent) *

EKSEMPLER PÅ HULLBILDER

Materiale: SS 1142/St 12.03 DIN 1623
 SS 1312/StW 22 DIN 1541

Hullstr. w
 + mellomrom c
 = Deling

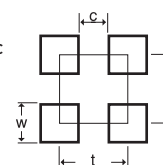

Firkantperforering firkantdeling

(DIN 24042) Qg w - t	a0* i %	1000 x 2000 mm tykk. i mm						1250 x 2500 mm tykk. i mm				1500 x 3000 mm tykk. i mm			
Qg 3,0 - 5,0	36,0	1,0													
Qg 4,0 - 7,0	32,7	1,0	1,5												
Qg 5,0 - 8,0	39,1	1,0	1,5	2,0				1,0	1,5			1,5			
Qg 5,0 - 16,0	12,3							1,5							
Qg 6,0 - 9,0	44,4	1,0	1,5	2,0											
Qg 8,0 - 12,0	44,4	1,0	1,5	2,0	1,0			1,5	2,0	1,5	2,0				
Qg 8,0 - 24,0	11,1	1,5													
Qg 9,2 - 34,0	7,0	1,5													
Qg 10,0 - 12,0	69,4	1,0	1,5	2,0				1,5							
Qg 10,0 - 14,0	51,0	1,0	1,5	2,0				1,5	2,0						
Qg 10,0 - 15,0	44,4	1,0	1,5	2,0	3,0			1,0	1,5	2,0	1,0	1,5	2,0		
Qg 15,0 - 20,0	56,2	1,0	1,5	2,0	3,0			1,5	2,0	2,0					
Qg 15,0 - 60,0	6,3							2,0							
Qg 20,0 - 25,0	64,0							2,0							
Qg 20,0 - 50,0	16,0							2,0							
Qg 25,0 - 30,0	69,4							2,0							
Qg 25,0 - 35,0	51,0							2,0							
Qg 25,0 - 70,0	12,8							2,0							

Slisseperforering triangeldeling

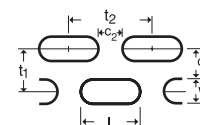

(DIN 24043) Lv w - t	a0* i %	1000 x 2000 mm tykk. i mm						1250 x 2500 mm tykk. i mm				1500 x 3000 mm tykk. i mm			
Lv 2 x 20	31,0	2,0													
Lv 3 x 20	35,0	1,5													
Lv 5 x 20	42,0	1,0	1,5	2,0											

Dekorasjonsperforering

(DIN 24043) Lv w - t	a0* i %	1000 x 2000 mm tykk. i mm						1250 x 2500 mm tykk. i mm				1500 x 3000 mm tykk. i mm			
Nr. 152 kløver	45,0	1,0	1,5												
Nr. 45 rotting	30,0	1,0													

Vekt pr. m² = 8 kg x tykkelsen - Ao% (luft prosent) *

EKSEMPLER PÅ HULLBILDER

Materiale: SS 1152 Sendzimir

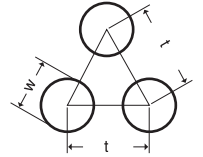

Runde hull triangeldeling

(DIN 24041) Rv	w - t	a0* i %	1000 x 2000 mm tykk. i mm				1250 x 2500 mm tykk. i mm				1500 x 3000 mm tykk. i mm			
Rv 1,5 - 2,5		32,7	1,0											
Rv 2,0 - 3,5		29,6	1,0											
Rv 3,0 - 4,0		51,0	0,7											
Rv 3,0 - 5,0		32,7	0,7	1,0	1,5	2,0		0,7	1,0			1,0	1,5	
Rv 4,0 - 6,0		40,3	0,7	1,0				0,7	1,0			1,0		
Rv 5,0 - 7,0		46,3	0,7	1,0	1,5			0,7	1,0			1,0		
Rv 5,0 - 8,0		35,4	0,7	1,0	1,5	2,0		0,7	1,0	1,5	2,0	1,0	1,5	2,0
Rv 8,0 - 10,0		58,0	0,7											
Rv 8,0 - 11,0		48,0	1,0	1,5	2,0									
Rv 8,0 - 12,0		40,3	1,0	1,5	2,0			1,0	1,5	2,0				
Rv 10,0 - 14,0		46,3	1,0											
Rv 10,0 - 15,0		40,3	1,5	2,0	4,0			1,0	1,5	2,0		1,5	2,0	
Rv 15,0 - 21,0		46,3						1,5	2,0					
Rv 20,0 - 28,0		46,3	2,0					1,5	2,0					
Varmgalvaniserte plater														
Rv 6,0 - 9,0		40,3	6,0											
Rv 8,0 - 15,0		33,0	8,0											

Runde hull firkantdeling

(DIN 24041) Rg	w - t	a0* i %	1000 x 2000 mm tykk. i mm				1250 x 2500 mm tykk. i mm				1500 x 3000 mm tykk. i mm			
Rg 4,5 - 15,0		7,1	1,0	1,5				1,5				1,5		
Rg 10,0 - 20,78		18,18	2,0											

Hullstr. w
+ mellomrom c
= Deling

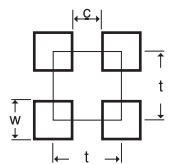

Firkanthull firkantdeling

(DIN 24042) Qg	w - t	a0* i %	1000 x 2000 mm tykk. i mm				1250 x 2500 mm tykk. i mm				1500 x 3000 mm tykk. i mm			
Qg 5,0 - 7,5		44,4	1,0											
Qg 5,0 - 8,0		39,1	1,0	1,5				1,0	1,5	2,0				
Qg 7,0 - 10,0		49,0	1,0											
Qg 8,0 - 10,0		64,0	1,0	1,5										
Qg 8,0 - 12,0		44,4	1,0	1,5	2,0			1,5						
Qg 9,0 - 12,5		51,8	1,0											
Qg 10,0 - 12,0		69,4	1,0					1,5						
Qg 10,0 - 14,0		51,0	1,0	1,5				1,0	1,5					
Qg 10,0 - 15,0		44,4	1,0	1,5	2,0			1,0	1,5	2,0		1,5	2,0	

Vekt pr. m² = 8 kg x tykkelsen - Ao% (luft prosent) *

EKSEMPLER PÅ HULLBILDER

Materiale: SS 2333 / 1.4301

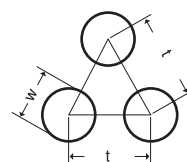

Runde hull triangeldeling

(DIN 24041) Rv w - t	a0* i %	1000 x 2000 mm tykk. i mm						1250 x 2500 mm tykk. i mm				1500 x 3000 mm tykk. i mm			
Rv 1,1 - 2,0	27,4	0,8													
Rv 1,5 - 2,5	32,7	0,5	1,0												
Rv 2,0 - 3,5	29,6	1,0	1,5					1,0	1,5						
Rv 3,0 - 5,0	32,7	0,5	0,8	1,0	1,5	2,0	1,0	1,5							
Rv 4,0 - 6,0	40,3	1,0	1,5					1,0							
Rv 5,0 - 7,0	46,3	0,5	1,0												
Rv 5,0 - 8,0	35,4	1,0	1,5	2,0	3,0			0,8	1,0	1,5	2,0	1,0	1,5		
Rv 6,0 - 8,0	51,0	1,0													
Rv 6,0 - 9,0	40,3	1,5													
Rv 8,0 - 11,0	48,3	1,0	1,5	2,0											
Rv 8,0 - 12,0	40,3	1,0	1,5	2,0	3,0			1,0	1,5	2,0					
Rv 10,0 - 13,0	53,7	1,0													
Rv 10,0 - 15,0	40,3	1,0	1,5	2,0	3,0			1,0	1,5	2,0		1,5	2,0		
Rv 15,0 - 21,0	46,3	1,5													
Rv 20,0 - 28,0	46,3	2,0						2,0							

Runde hull firkantdeling

(DIN 24041) Rg w - t	a0* i %	1000 x 2000 mm tykk. i mm						1250 x 2500 mm tykk. i mm				1500 x 3000 mm tykk. i mm			
Rg 4,5 - 15,00	7,1	1,5													
Rg 15,0 - 36,38	13,35	1,5													
Rg 20,0 - 48,50	13,35	1,5													

Hullstr. w
+ mellomrom c
= Deling

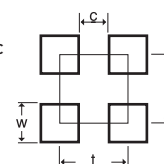

Firkantpeforering firkantdeling

(DIN 24042) Qg w - t	a0* i %	1000 x 2000 mm tykk. i mm						1250 x 2500 mm tykk. i mm				1500 x 3000 mm tykk. i mm			
Qg 5,0 - 8,0	39,1	1,0	1,5	2,0				1,5							
Qg 8,0 - 10,0	64,0	1,0	1,5												
Qg 8,0 - 12,0	44,4	1,0	1,5					1,0							
Qg 10,0 - 12,0	69,4	0,5	1,0	1,5				1,5							
Qg 10,0 - 14,0	51,0	1,0	2,0												
Qg 10,0 - 15,0	44,4	1,0	1,5	2,0				1,0	1,5	2,0		2,0			
Qg 15,0 - 40,0	14,0	1,5													
Qg 20,0 - 50,0	16,0	1,5													

Vekt pr. m² = 8 kg x tykkelsen - A0% (luft prosent) *

EKSEMPLER PÅ HULLBILDER

Materiale: SS 2350/1.4571

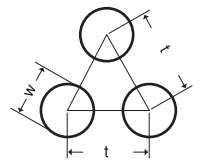

Runde hull triangeldeling

(DIN 24041) Rv	w - t	a0* i %	1000 x 2000 mm tykk. i mm				1250 x 2500 mm tykk. i mm				1500 x 3000 mm tykk. i mm			
Rv	2,0 - 3,5	29,6	1,0	1,5										
Rv	3,0 - 5,0	32,7	1,0	1,5	2,0									
Rv	5,0 - 8,0	35,4	1,0	1,5	2,0	3,0								
Rv	10,0 - 15,0	40,3	1,0	1,5	2,0									

Hullstr. w
+ mellomrom c
= Deling

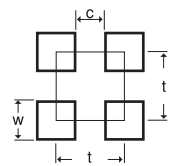

Firkant hull firkantdeling

(DIN 24042) Qg	w - t	a0* i %	1000 x 2000 mm tykk. i mm				1250 x 2500 mm tykk. i mm				1500 x 3000 mm tykk. i mm			
Qg	8,0 - 12,0	44,4	1,0											
Qg	10,0 - 15,0	44,4	1,5	2,0										

Vekt pr. m² = 8 kg x tykkelsen - Ao% (luft prosent) *

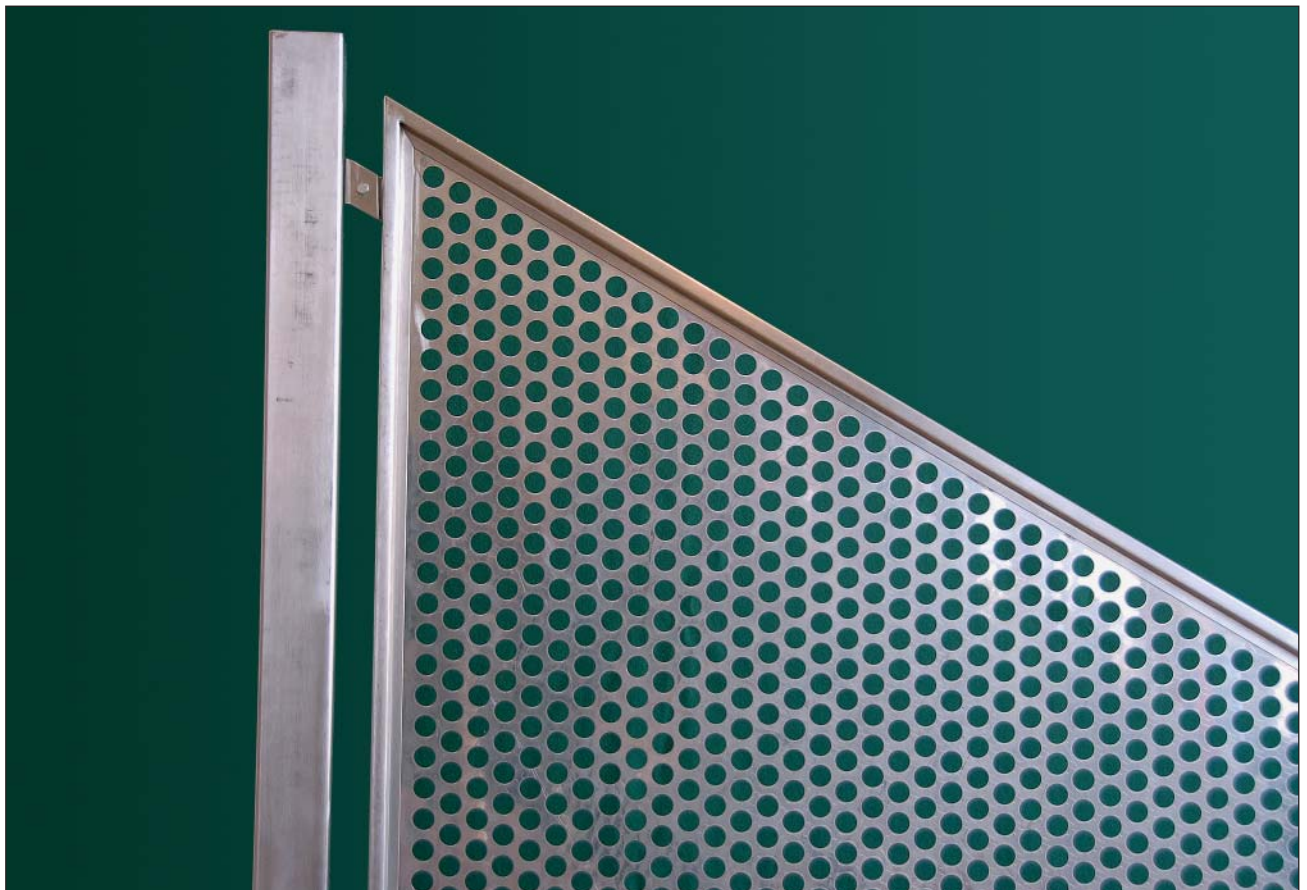

ALUMINIUM PLATER

EKSEMPLER PÅ HULLBILDER

Materiale: SS 4007 / Al 99,5% hh

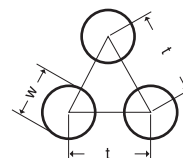

Runde hull triangeldeling

(DIN 24041) Rv	w - t	a0* i %	1000 x 2000 mm tykk. i mm					1250 x 2500 mm tykk. i mm				1500 x 3000 mm tykk. i mm			
Rv 1,5 - 2,5		32,7	1,0												
Rv 2,0 - 3,5		29,6	1,0	1,5											
Rv 3,0 - 4,0		51,0	0,8												
Rv 3,0 - 5,0		32,7	0,7	0,8	1,0	1,5	2,0	1,5	2,0						
Rv 4,0 - 6,0		40,3	1,0	1,5	2,0										
Rv 5,0 - 8,0		35,4	1,0	1,5	2,0	3,0		1,0	1,5	2,0	3,0	1,0	1,5	2,0	
Rv 6,0 - 9,0		40,3	1,0	1,5	2,0										
Rv 8,0 - 10,0		58,0	0,8												
Rv 8,0 - 12,0		40,3	1,0	1,5	2,0			2,0							
Rv 10,0 - 12,0		63,0						1,5							
Rv 10,0 - 15,0		40,3	1,0	1,5	2,0	3,0		1,5	2,0			2,0			
Rv 15,0 - 21,0		46,3	2,0					2,0							
Rv 20,0 - 28,0		46,3	2,0					2,0				2,0			

Runde hull firkantdeling

(DIN 24041) Rg	w - t	a0* i %	1000 x 2000 mm tykk. i mm					1250 x 2500 mm tykk. i mm				1500 x 3000 mm tykk. i mm			
Rg 4,5 - 15,00		7,1	1,5	2,0				1,5							
Rg 10,0 - 20,78		18,18	2,0					2,0							
Rg 10,0 - 25,98		11,63	2,0					2,0							
Rg 15,0 - 36,38		13,35	2,0					2,0							
Rg 20,0 - 48,50		13,35	2,0					2,0							

Hullstr. w
+ mellomrom c
= Deling

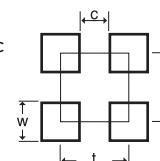

Firkanthull firkantdeling

(DIN 24042) Qg	w - t	a0* i %	1000 x 2000 mm tykk. i mm					1250 x 2500 mm tykk. i mm				1500 x 3000 mm tykk. i mm			
Qg 4,0 - 7,0		32,7	1,5												
Qg 5,0 - 8,0		39,1	1,0	1,5	2,0										
Qg 6,0 - 9,0		44,4	1,0	1,5											
Qg 8,0 - 12,0		44,4	1,0	1,5	2,0			2,0							
Qg 8,0 - 24,0		11,1	2,0												
Qg 10,0 - 15,0		44,4	1,0	1,5	2,0	3,0		1,5	2,0	3,0		2,0			
Qg 10,0 - 30,0		11,1	2,0												
Qg 15,0 - 60,0		6,3						2,0							
Qg 20,0 - 50,0		16,0						2,0							
Qg 25,0 - 30,0		69,4						2,0							
Qg 25,0 - 70,0		12,8						2,0							

Vekt pr. m² = 2,7 kg x tykkelsen - Ao% (luft prosent) *

EKSEMPLER PÅ HULLBILDER

Materiale: SS 4007 / Al 99,5% hh

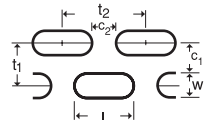

Slisseperforering triangeldeling

(DIN 24043) Lv w - t	a0* i %	1000 x 2000 mm tykk. i mm	1250 x 2500 mm tykk. i mm	1500 x 3000 mm tykk. i mm
Lv 2,0 - 20,0	32,62	2,0		
Lv 3,0 - 20,0	40,32	2,0		
Lv 5,0 - 20,0	43,81	2,0		

Materiale: Al Mg 3 hh

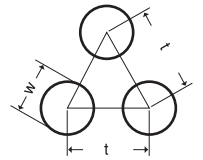

Runde hull triangeldeling

(DIN 24041) Rv w - t	a0* i %	1000 x 2000 mm tykk. i mm	1250 x 2500 mm tykk. i mm	1500 x 3000 mm tykk. i mm
Rv 2,0 - 3,5	29,6	1,0		
Rv 3,0 - 5,0	32,7	1,0 1,5 2,0	1,0 1,5 2,0	
Rv 5,0 - 8,0	35,4	1,0 1,5 2,0	1,0 1,5	
Rv 8,0 - 12,0	40,3	1,5 2,0		
Rv 10,0 - 15,0	40,3	1,5	1,5 2,0	

Hullstr. w
+ mellomrom c
= Deling

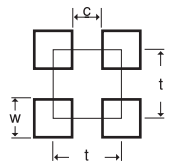

Firkant hull firkantdeling

(DIN 24042) Qg w - t	a0* i %	1000 x 2000 mm tykk. i mm	1250 x 2500 mm tykk. i mm	1500 x 3000 mm tykk. i mm
Qg 5,0 - 8,0	39,1	1,0 1,5 2,0	2,0	
Qg 8,0 - 12,0	44,4	1,0 1,5 2,0	2,0	

Vekt pr. m² =
2,7 kg x tykkelsen - Ao% (luft prosent) *

Leveres på forespørsel:

- KOBBERPLATER
- TITANSINKPLATER

PROFILER TIL PERFORERTE PLATER

Profiler dere med våre profiler!

PRODUKTDATA

Godstykkelse:

1,25 mm og 1,5 mm

Lengde:

3000 mm

Materiale:

Stål, galvanisert stål, aluminium og rustfritt.

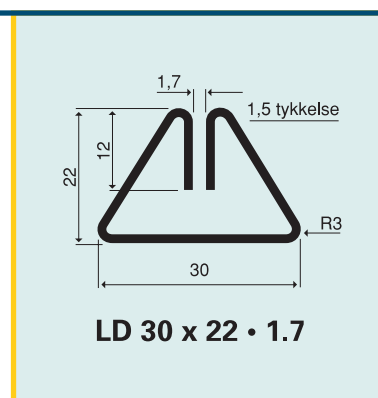
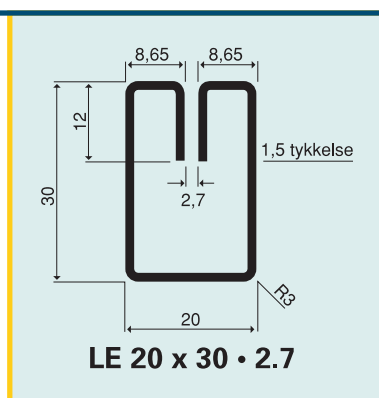
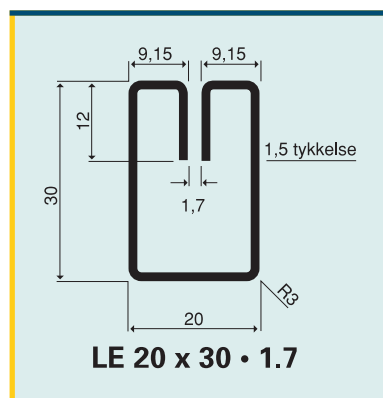
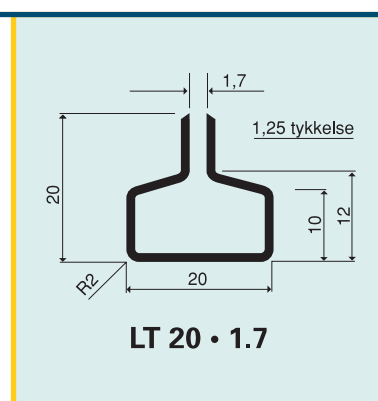
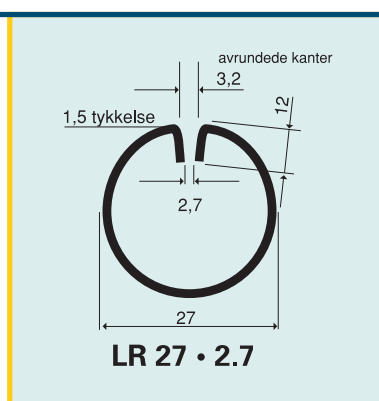
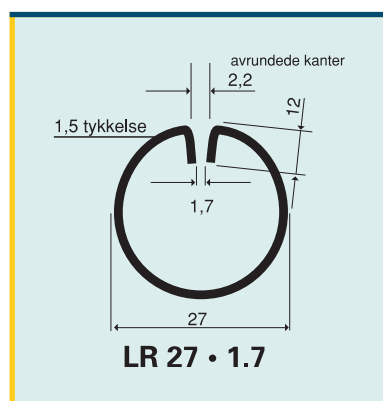
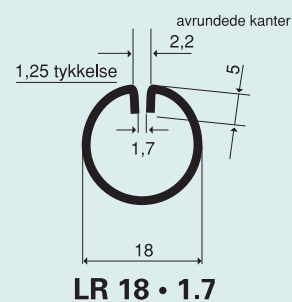

Syv profiler - et overblikk

Type	Mål	Mtr.tykk. i mm	Slissebr. i mm	Materiale				
				Stål	Galv.	Al 99,5	Aisi 304	Aisi 304 slipt/folie
LR	18 • 1,7	1,25	1,7	●	●	●	●	●
LR	27 • 1,7	1,5	1,7	●	●	●	●	●
LR	27 • 2,7	1,5	2,7	●				
LT	20 x 20 • 1,7	1,25	1,7	●	●	●	●	
LE	20 x 30 • 1,7	1,5	1,7	●	●	●	●	●
LE	20 x 30 • 2,7	1,5	2,7	●				
LD	30 x 22 • 1,7	1,5	1,7	●	●	●	●	

Nye eksklusive hullmønstre!

Slike mønstre har du kanskje aldri sett før!
Europas største produsent av perforerte plater har nå utviklet en ny type mønstre.

Program:

Disse hullmønstre finnes i materiale og format som vist på denne siden: (Skala 1:6)

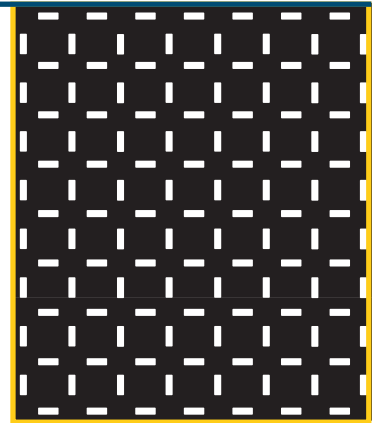

Kvadrat RE 5x15-35x35
a_o*: 11,6%

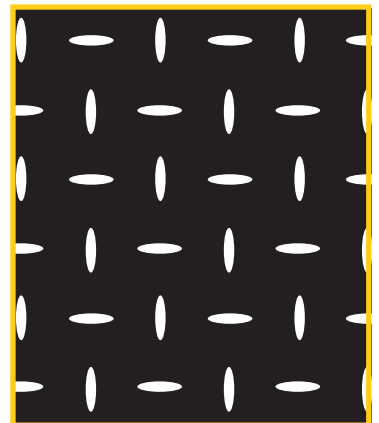

Ellipse E VH 8x32-50x50
a_o*: 8,0%

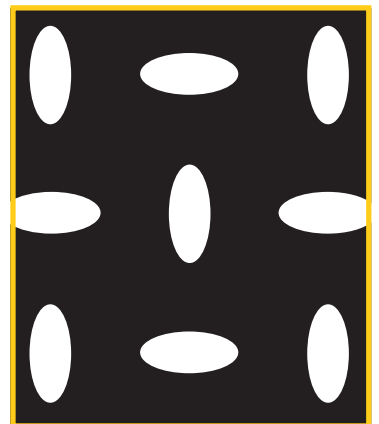

Ellipse E VH 30x70-100x100
a_o*: 16,5%

Tykkelse i mm	Stål Mål i mm	Al 99,5 Mål i mm	Aisi 304 Mål i mm	Aisi 304 slipt foliert 2 sider
1,5			1000 x 2000/1250 x 2500	1000 x 2000
2,0	1000 x 2000	1000 x 2000		
2,0		1250 x 2500		

*) Relativt hullareal

Åtte strukturplater å begynne med

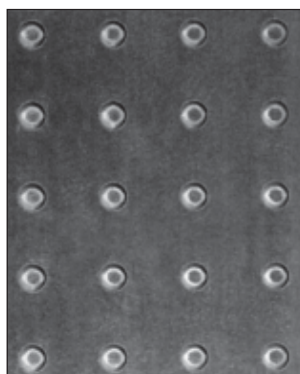

Rsg 10-30 Stål

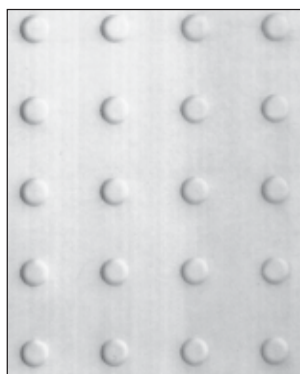

Rsg 10-30 Aisi 304

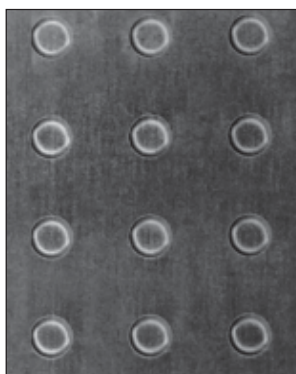

Rsg 15-36 Stål

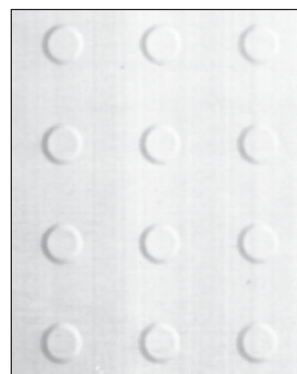

Rsg 15-36 AL 99,5

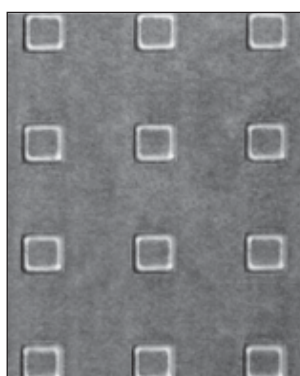

Qsg 15-40 Stål

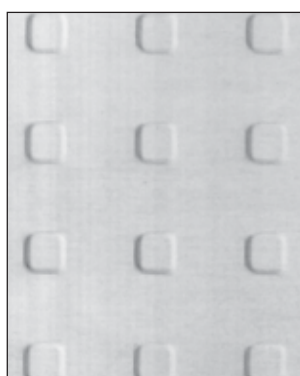

Qsg 15-40 AL 99,5

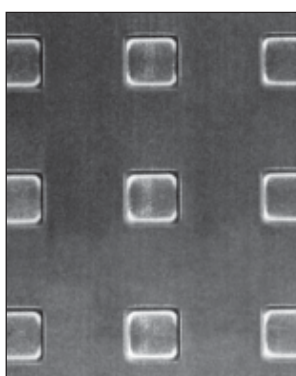

Qsg 20-50 Stål



Qsg 20-50 AL 99,5

Tekniske data:

Strukturplatene leveres i format 1000 x 2000 mm eller 1250 x 2500 mm med rund eller firkantet preging

Tykkelse:

1,5 mm eller 2,0 mm

Materiale:

• Stål • Aluminium • Rustfritt • Aisi 304

Pregingsdybden er 0,4 mm og det er ca. 25 mm upreget kant på alle sider.

Planheten er lik som for perforerte plater.

Andre preginger og formater/
materialer på forespørsel.

	Preging	Materiale	Tykkelse
Rsg	10-30	Stål	1,5/2,0 mm
Rsg	10-30	Aisi 304	1,5 mm
Rsg	15-36	Stål	1,5/2,0 mm
Rsg	15-36	Al 99,5	2,0 mm
Rsg	15-36	Aisi 304	1,5 mm
Rsg	20-50	Aisi 304	1,5 mm
Qsg	15-40	Aisi 304	1,5 mm
Qsg	15-40	Stål	1,5/2,0 mm
Qsg	15-40	Al 99,5	2,0 mm
Qsg	20-50	Stål	1,5/2,0 mm
Qsg	20-50	Al 99,5	2,0 mm